



Data Sheet

Customer: _____

Part No: _____

CL-BITZ1608UHY-02 (역칩+)

Sample No: _____

Description: _____

Item No: _____

Customer			
Check	Inspection	Approval	Date

SMD · CHIP



Features

- . 0603package
- . Top view LED
- . Compatible with infrared and vapor phase reflow solder process.
- . Wide viewing angle
- . Pb-free
- . RoHS compliant

Description

- . CIELLIGHT192 package has high efficacy, high power consumption, wide viewing angle and a compact form factor.
- . These features make this package an ideal LED for all lighting applications.

Applications

- . General lighting
- . Decorative and Entertainment Lighting
- . Indicators
- . Automotive Telecommunication
- . Switch lights

Device Selection Guide

Chip Material	Emitted Color	Resin Color
AlGaInP	Brilliant Yellow	Water Clear

Absolute Maximum Ratings (Ta=25°C)

Parameter	Symbol	Rating	Unit
Continuous Forward Current	I _F	30	mA
Operating Temperature	T _{opr}	-40 ~ +85	°C
Storage Temperature	T _{stg}	-40 ~ +100	°C
Peak Forward Current (T=1.3s, tp=0.3s)	I _{FP}	80	mA
Soldering Temperature* ¹	T _{sol}	Reflow Soldering : 260 °C Hand Soldering : 350 °C	for 10 sec. for 3 sec.
Power Dissipation at(or below) 25°C Free Air Temperature	P _d	75	mW
Electrostatic Discharge(HBM)	ESD	2000	V

Notes: *1: Soldering time ≤ 5 seconds.

Electro-Optical Characteristics (Ta=25°C)

Parameter	Symbol	Min.	Typ.	Max.	Unit	Condition
Forward Voltage	V _F	1.8	---	2.3	V	I _F =20mA
Reverse Current	I _R	---	---	10	μA	V _R =5V
Dominant Wavelength	λ _d	584	---	594	nm	I _F =20mA
Luminous Intensity	I _v	180	---	450	mcd	I _F =20mA
Viewing Angle	2θ _{1/2}	---	120	---	deg	I _F =20mA

Notes:

1. Tolerance of Luminous Intensity ±10%.
2. Tolerance of Forward Voltage : ±0.05V.

Bin Range of Luminous Flux

Bin Code	Min	Max	Unit	Condition
AS1	180	225	mcd	I _F =20mA
AS2	225	280		
AT1	280	360		
AT2	360	450		

Note:

Tolerance of Luminous Flux: ±10%.

Bin Range of Forward Voltage

Bin Code	Min	Max	Unit	Condition
18	1.8	1.9	V	I _F =20mA
19	1.9	2.0		
20	2.0	2.1		
21	2.1	2.2		
22	2.2	2.3		

Note:

Tolerance of Forward Voltage: ±0.1V.

Bin Range of Dominant Wavelength

Bin Code	Min	Max	Unit	Condition
58C	584	586	nm	I _F =20mA
58D	586	588		
58E	588	590		
59A	590	592		
59B	592	594		

Note:

1. The value is based on driving current by 20mA.
2. Tolerance of Dominant Wavelength: : ±1nm..

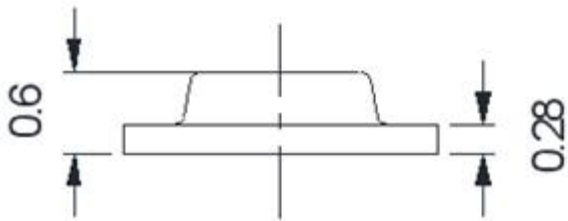
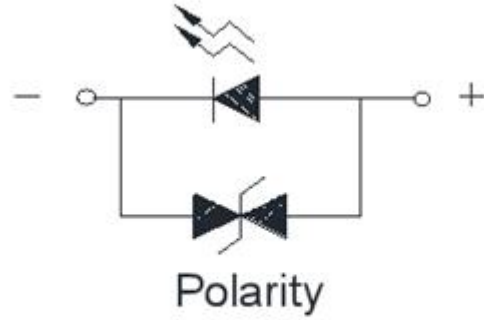
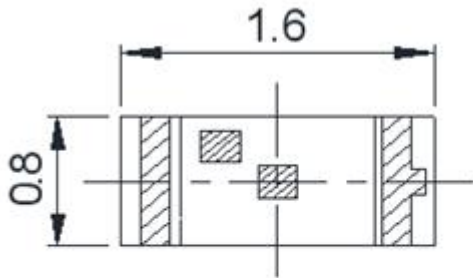
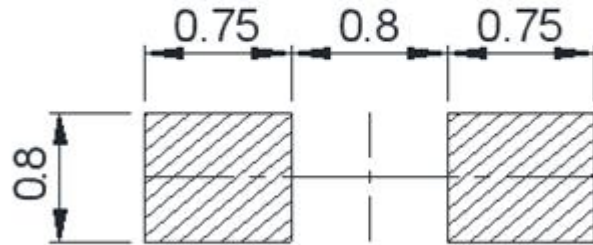
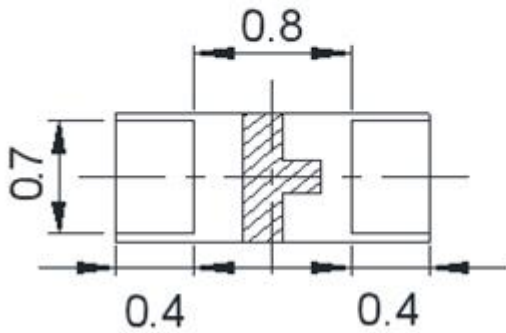
Package Dimensions

Recommended Solder Pad

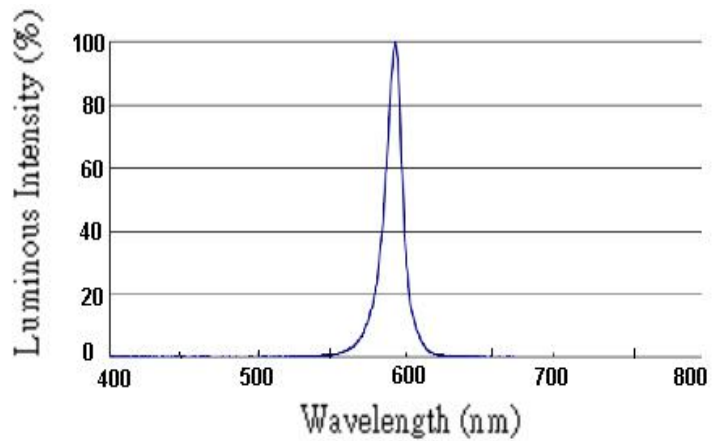
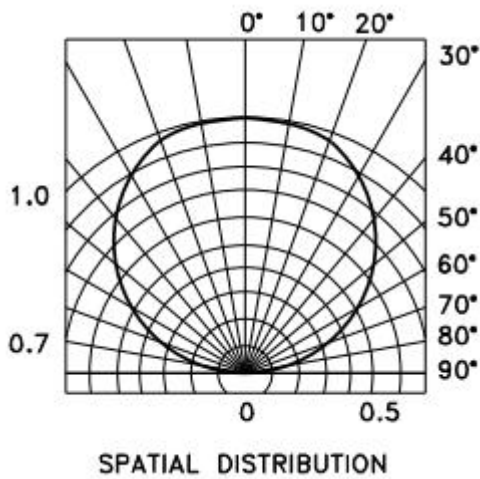
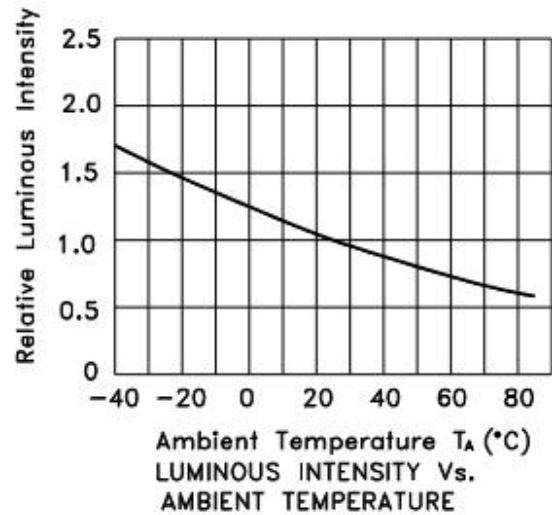
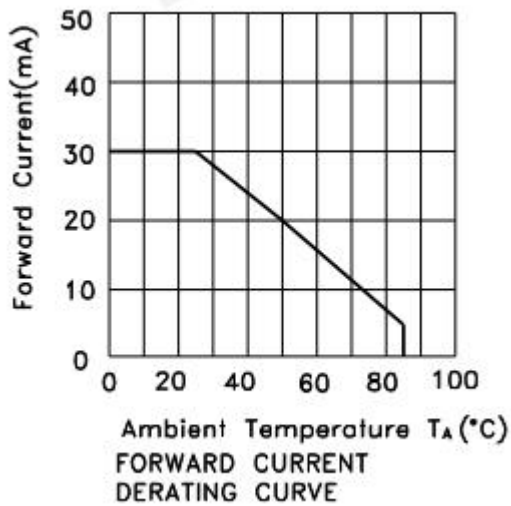
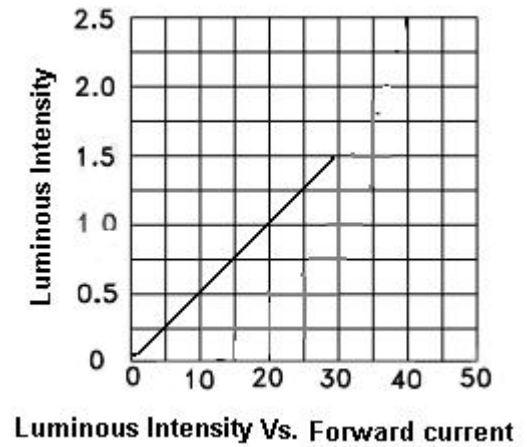
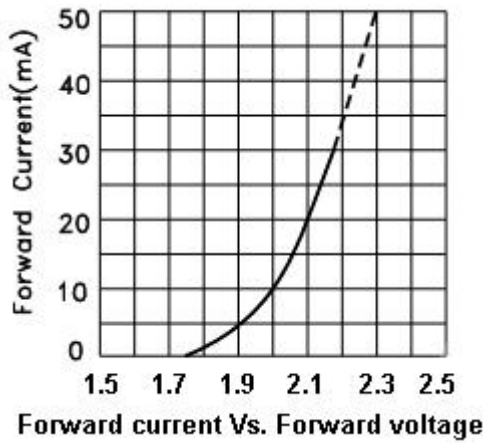
Note:

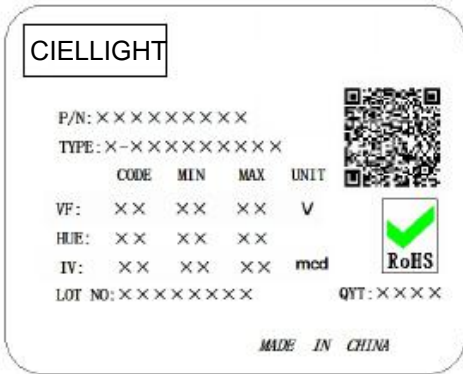
Tolerance unless mentioned is ± 0.1 mm, Unit = mm.



Label Form Specification

CPN: Customer's Production Number

P/N : Production Number

QTY: Packing Quantity

CAT: Ranks

HUE: Peak Wavelength

REF: Reference

LOT No: Lot Number

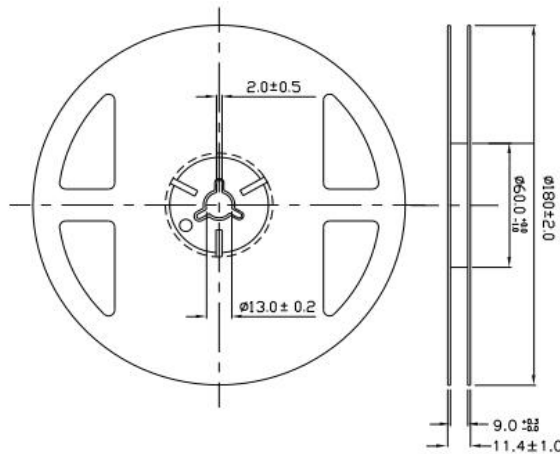
Reel Dimensions

Note: The tolerances unless mentioned is $\pm 0.1\text{mm}$, Unit = mm

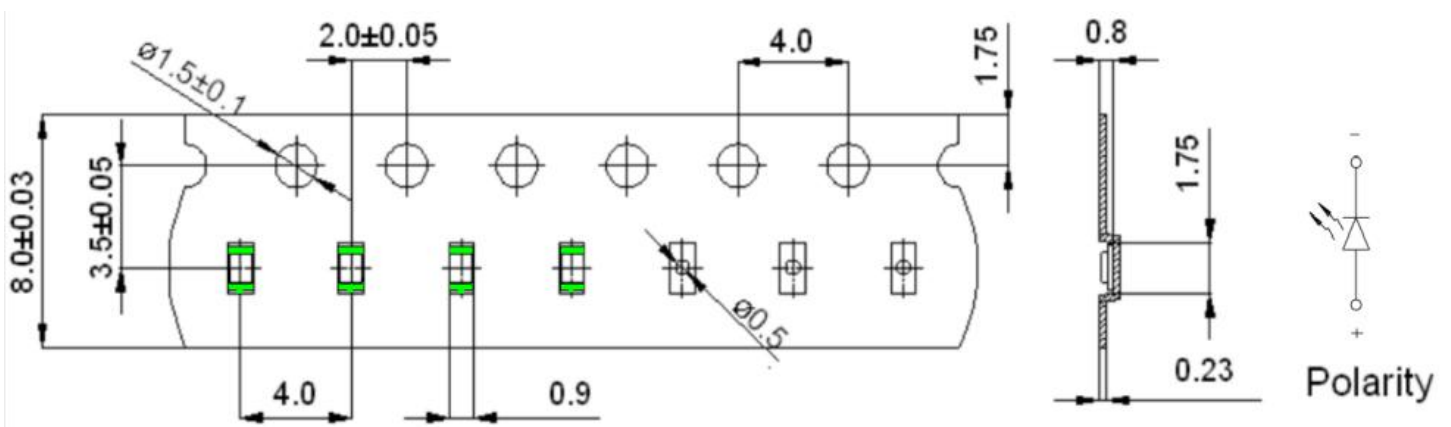
Carrier Tape Dimensions:(Quantity: 4000pcs/reel)

Note:

1. Tolerance unless mentioned is $\pm 0.1\text{mm}$, Unit = mm.
2. Minimum packing amount is 1000/2000 pcs per reel.

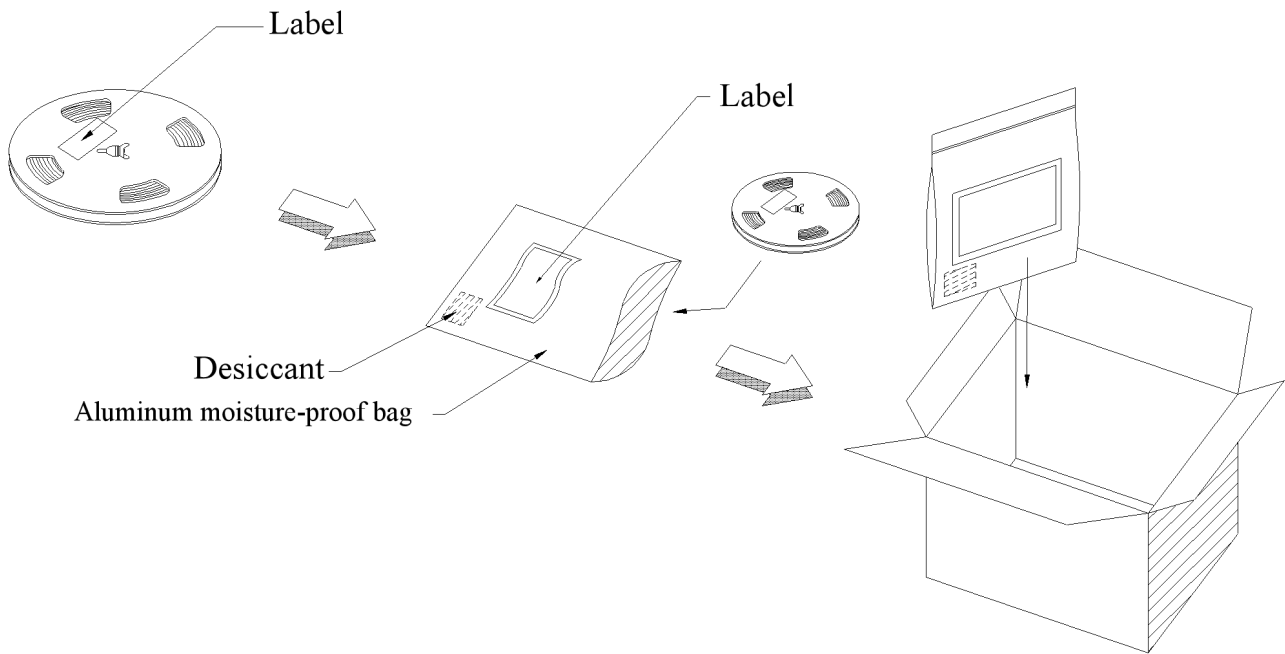
Moisture Resistant Packing Process



Reliability Test Items and Conditions

The reliability of products shall be satisfied with items listed below.

Confidence level : 90%

LTPD : 10%

No.	Items	Test Condition	Test Hours/Cycles	Sample Size	Ac/Re
1	Reflow Soldering	Temp. : 260°C/10sec.	6 Min	22 PCS	0/1
2	Thermal Shock	H : +100°C 5min ∫ 10 sec L : -10°C 5min	300 Cycles	22 PCS	0/1
3	Temperature Cycle	H : +100°C 15min ∫ 5 min L : -40°C 15min	300 Cycles	22 PCS	0/1
4	High Temperature/Humidity Reverse Bias	Ta=85°C,85%RH	1000 Hrs.	22 PCS	0/1
5	Low Temperature Storage	Ta=-40°C	1000 Hrs.	22 PCS	0/1
6	High Temperature Storage	Ta=100°C	1000 Hrs.	22 PCS	0/1
7	DC Operation Life	Ta=25°C IF = 20 mA	1000 Hrs.	22 PCS	0/1

Precautions For Use

1. Over-current-proof

Customer must apply resistors for protection, otherwise slight voltage shift will cause big current change (Burn out will happen).

2. Storage

2.1 Do not open moisture proof bag before the products are ready to use.

2.2 Before opening the package, the LEDs should be kept at 40°C or less and 90%RH or less.

2.3 The LEDs should be used within a year.

2.4 After opening the package, the LEDs should be kept at 30°C or less and 60%RH or less.

2.5 The LEDs should be used within 168 hours (7 days) after opening the package

2.6 If the moisture absorbent material (silica gel) has faded away or the LEDs have exceeded the storage time, baking treatment should be performed using the following J-STD-33 Standard.

3. Soldering Condition

3.1 Pb-free solder temperature profile

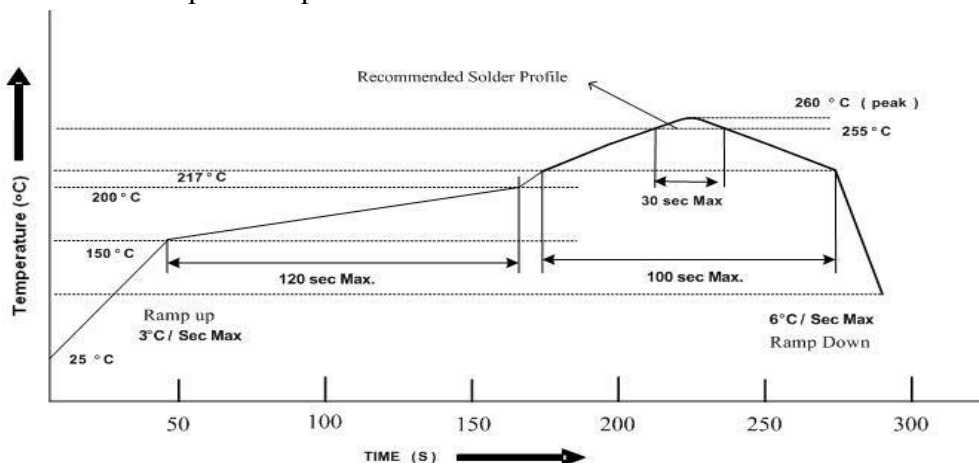

3.2 Reflow soldering should not be done more than two times.

3.3 When soldering, do not put stress on the LEDs during heating.

3.4 After soldering, do not warp the circuit board.

4. Soldering Iron

Each terminal is to go to the tip of soldering iron temperature less than 350°C for 3 seconds within once in less than the soldering iron capacity 25W. Leave two seconds and more intervals, and do soldering of each terminal. Be careful because the damage of the product is often started at the time of the hand solder.

5. Repairing

Repair should not be done after the LEDs have been soldered. When repairing is unavoidable, a double-head soldering iron should be used (as below figure). It should be confirmed beforehand whether the characteristics of the LEDs will or will not be damaged by repairing.